

HEAT CONTROLLER, INC.

Comfort-Caire[®]

Room Air Conditioner

**MODELS: REG-71A
REG-123A**

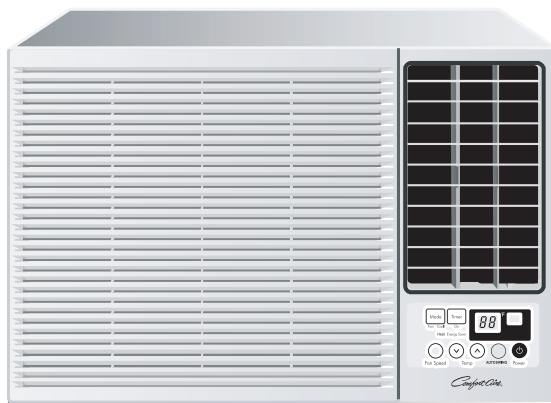

SERVICE MANUAL

CAUTION

- BEFORE SERVICING THE UNIT, READ THE SAFETY PRECAUTIONS IN THIS MANUAL.
- ONLY FOR AUTHORIZED SERVICE PERSONNEL

TABLE OF CONTENTS

- Safety Precautions**3
- Dimensions**5
 - Symbols Used in this Manual5
 - Outside Dimensions5
- Product Specifications**6
- Installation**7
 - Select the Best Location7
 - Installation Check7
 - How to Secure the Drain Pipe(When using drain pipe)7
 - How to Install(Models without Installation Kit)8
 - How to Install(Models with Installation Kit)9
 - Suggested Tool Requirements11
- Operation**14
 - Features14
 - Control Locations Function of Controls14
- Disassembly**15
 - Mechanical Parts15
 - Air Handling Parts16
 - Electrical Parts17
 - Refrigerating Cycle19
- Schematic Diagram**22
 - Wiring Diagram22
- Troubleshooting Guide**23
 - Piping System23
 - Troubleshooting Guide24
 - Room Air Conditioner Voltage Limits26

Safety Precautions



To prevent injury to the user or other people and property damage, the following instructions must be followed.

- Incorrect operation due to ignoring instruction will cause harm or damage. The seriousness is classified by the following indications.

⚠ WARNING This symbol indicates the possibility of death or serious injury.

⚠ CAUTION This symbol indicates the possibility of injury or damage to property only.

- Meanings of symbols used in this manual are as shown below.

	Be sure not to do.
	Be sure to follow the instruction.

⚠ WARNING

■ Installation

Do not use damaged power cord plugs, or a loose socket.

- There is risk of fire or electric shock.

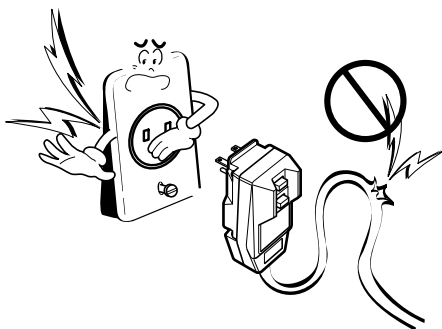

Always use the power plug and socket with the ground terminal.

- There is risk of electric shock.

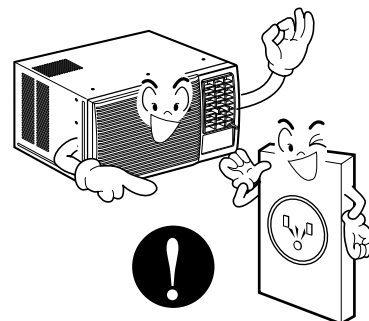

Do not modify or extend the power cord.

- There is risk of fire or electric shock.

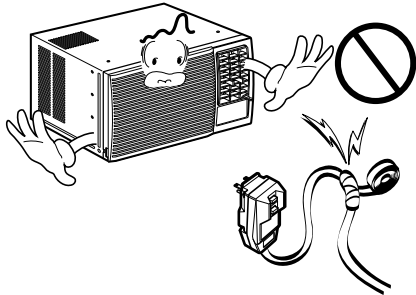

Do not install, remove, or re-install the unit by yourself(customer).

- There is risk of fire, electric shock, explosion, or injury.

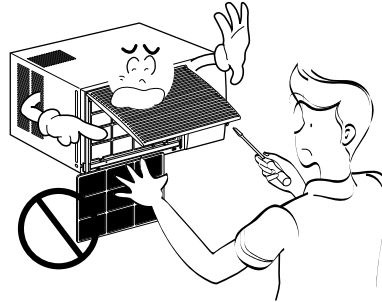

Be cautious when unpacking and installing the product.

- Sharp edges could cause injury. Be especially careful of the case edges and the fins on the condenser and evaporator.

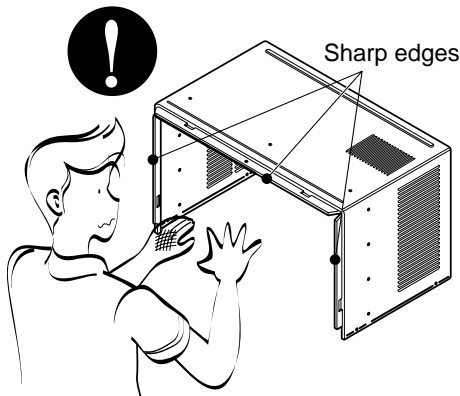

Do not store or use flammable gas or combustibles near the air conditioner.

- There is risk of fire or failure of product.

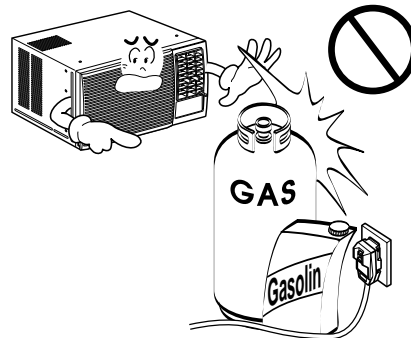

Be sure the installation area does not deteriorate with age.

- If the base collapses, the air conditioner could fall with it, causing property damage, product failure, and personal injury.

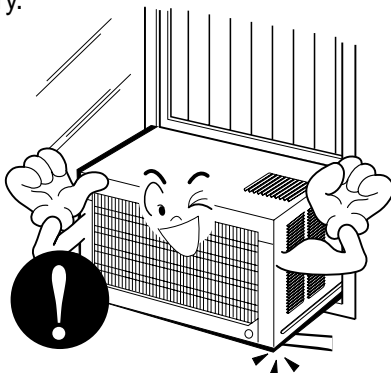

Dimensions

Symbols Used in this Manual



This symbol alerts you to the risk of electric shock.



This symbol alerts you to hazards that could cause harm to the air conditioner.

NOTICE

This symbol indicates special notes.

Outside Dimensions

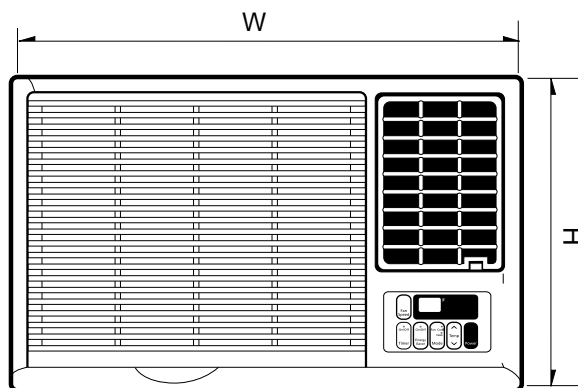
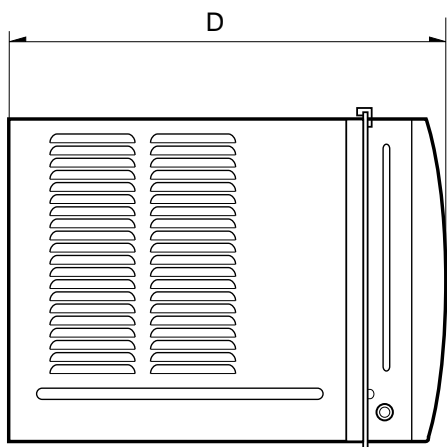

Dimension		Model	
		REG-71A	REG-123A
W	mm(inch)	471(18 ⁹ / ₁₆)	600(23 ⁵ / ₈)
H	mm(inch)	352(13 ⁷ / ₈)	380(14 ³¹ / ₂₂)
D	mm(inch)	525(20 ¹¹ / ₁₆)	576(22 ¹ / ₁₆)

Product Specifications

ITEMS		MODELS	REG-71A	REG-123A
POWER SUPPLY			1Ø, 115V, 60Hz	1Ø, 208/230V, 60Hz
COOLING CAPACITY		(Btu/h)	6,900	11,500/12,000
INPUT		(W)	710	1,170/1,220
RUNNING CURRENT		(A)	6.6	5.5/5.8
E.E.R		(BTU/W.h)	9.7	9.8/9.8
HEATING CAPACITY		(Btu/h)	3850	9,200/11,200
INPUT		(W)	1,260	2,900/3,500
RUNNING CURRENT		(A)	11.0	14.0/15.3
OPERATING CONDITION	COOLING	INDOOR(°C)	26.7 (DB)* 19.4 (WB)**	
		OUTDOOR(°C)	35 (DB)* 23.9 (WB)**	
	HEATING	INDOOR(°C)	21.1 (DB)* 15.6 (DB)**	
		OUTDOOR(°C)	8.3 (DB)* 6.1 (DB)**	
REFRIGERANT (R-22) CHARGE			385(13.6 oz)	605(21.3 oz)
EVAPORATOR			2ROW 14STACKS	2ROW 13STACKS
CONDENSER			2ROW 16STACKS	2ROW 17STACKS
FAN, INDOOR			BLOWER	
FAN, OUTDOOR			PROPELLER TYPE FAN WITH SLINGER-RING	
FAN SPEEDS, FAN/COOLING/HEATING			1 / 2 / 2	
FAN MOTOR			6 POLES	
OPERATION CONTROL			TOUCH PANEL	
ROOM TEMP. CONTROL			THERMISTOR	
AIR DIRECTION CONTROL			VERTICAL LOUVER(RIGHT&LEFT) HORIZONTAL LOUVER(UP&DOWN)	
CONSTRUCTION			SLIDE IN-OUT CHASSIS	
ELECTRIC HEATER			1.2KW, 115V	3.5KW, 230V
PROTECTOR	COMPRESSOR		OVERLOAD PROTECTOR	
	FAN MOTOR		INTERNAL THERMAL PROTECTOR	
	ELECTRIC HEATER		FUSE LINK, BIMETAL THERMOSTAT	
POWER CORD			1.6m(3 WIRE WITH GROUNDING)	
			ATTACHMENT PLUG(CORD-CONNECTED TYPE)	
DRAIN SYSTEM			DRAIN PIPE OR SPLASHED BY FAN SLINGER	
NET WEIGHT		(lbs/kg)	60/27	87/39
OUTSIDE DIMENSION (W x H x D)	(inch)		18 X 13 ⁷ / ₈ X 20 ¹¹ / ₁₆	23 ⁵ / ₈ X 14 ³¹ / ₂₂ X 22 ⁵ / ₁₆
	(mm)		470 X 353 X 525	600 X 380 X 525

* DB: Dry Bulb

** WB: Wet Bulb

NOTE: Please refer to Label Quality on the product since this specification may be changed for improving performance.

Installation

Select the Best Location

1. To prevent vibration and noise, make sure the unit is installed securely and firmly.
2. Install the unit where the sunlight does not shine directly on the unit.
3. The outside of the cabinet must extend outward for at least 12" and there should be no obstacles, such as a fence or wall, within 20" from the back of the cabinet because it will prevent heat radiation of the condenser. Restriction of outside air will greatly reduce the cooling efficiency of the air conditioner.



CAUTION: All side louvers of the cabinet must remain exposed to the outside of the structure.

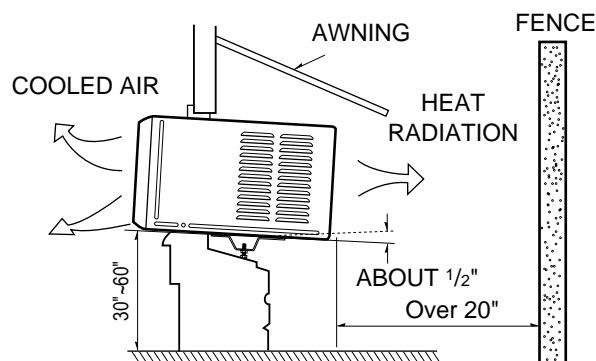

Figure 1

4. Install the unit a little slanted so the back is slightly lower than the front (about $\frac{1}{2}$ "). This will help force condensed water to the outside.
5. Install the unit from the bottom about 30"~60" above the floor level.

Installation Check

The setting conditions must be checked prior to initial starting.

The following items are especially important checking points when the installation is finished.

1. Grounding wire (Green or Green and Yellow) is provided in the power cord. The green wire must be grounded.
2. Connect to a single-outlet 15A circuit.
(or 20A circuit for Electric Heater Model)
3. To avoid vibration or noise, make sure the air conditioner is installed securely.
4. Avoid placing furniture or draperies in front of the air inlet and outlet.

How to Secure the Drain Pipe(When using drain pipe)

In humid weather, excess water may cause the BASE PAN to overflow. To drain the water, remove the DRAIN CAP and secure the DRAIN PIPE to the rear hole of the BASE PAN. Press the drain pipe into the hole by pushing down and away from the fins to avoid injury.

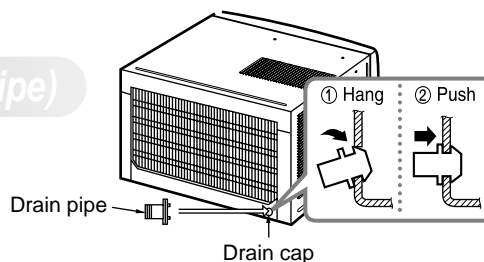

Optional

1. Install the drain pan over the corner of the cabinet where you removed the plug with 4 (or 2) screws.
2. Connect the drain hose to the outlet located at the bottom of the drain pan. You can purchase the drain hose or tubing locally to satisfy your particular needs. (Drain hose is not supplied).
3. Select the most appropriate connection from among the following figures (by considering the hole of the unit) to fit drain pan to your own unit.

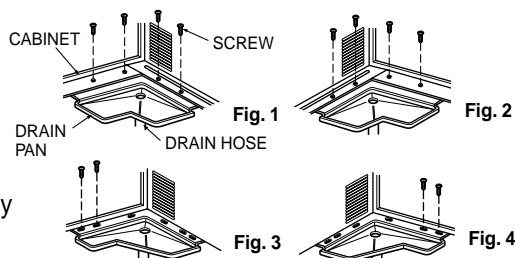

How to Install(Models without Installation Kit)

1. Remove the screws that fasten the cabinet at both sides and at the back.

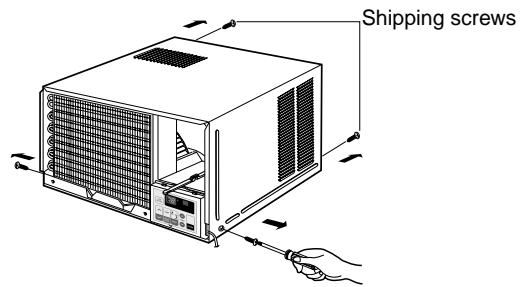

2. Slide the unit from the cabinet by gripping the base pan handle and pulling forward while bracing the cabinet.

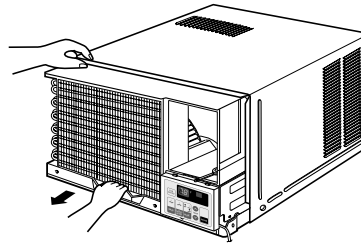

3. Remove EPS Material.

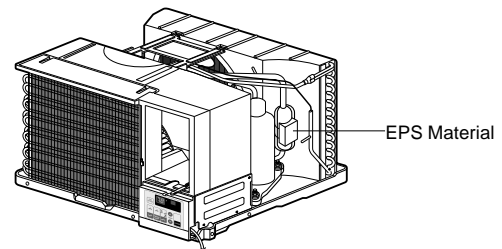

4. Slide the unit into the cabinet.



CAUTION: For security purpose, reinstall screw at cabinet's sides.

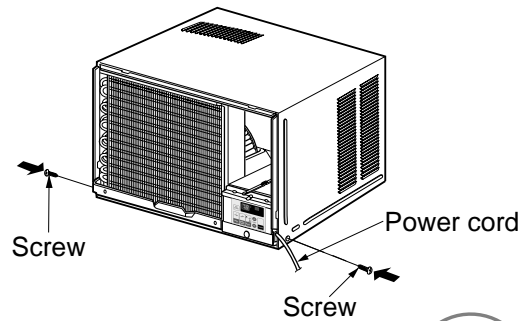

5. Attach the front grille to the cabinet by inserting the tabs on the grille into the tabs on the front of the cabinet. Push the grille in until it snaps into place.

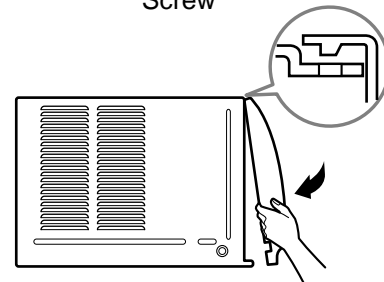

6. Lift the inlet grille and secure it with a screw through the front grille.

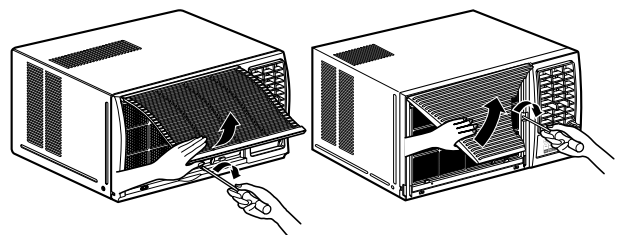

How to Install(Models with Installaion Kit)

When Using Gasket

REG-123A

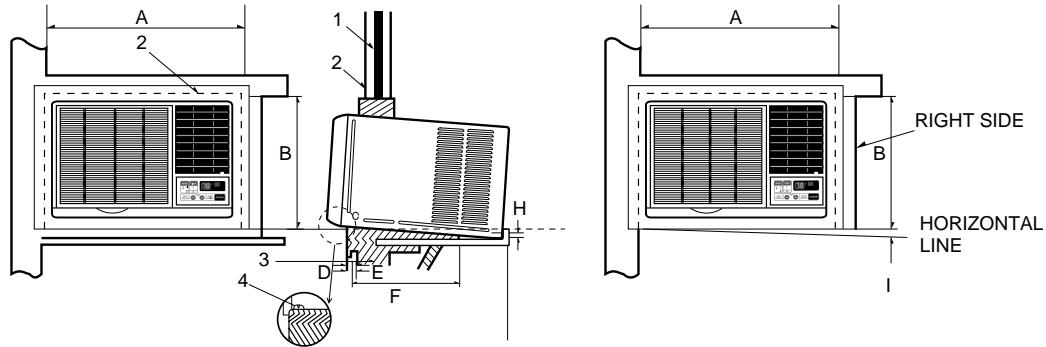

- 1. WINDOW (WIDTH-A, HEIGHT-B)
- 2. GASKET
- 3. WALL

- 4. DETAILS 5.1 x 30 ROUND HEAD WOOD SCREWS

A	B	C	D	E	F	H	I
625mm (24 ⁵ / ₈ ")	392mm (15 ⁷ / ₁₆ ")	280mm (11 ¹ / ₃₂ ")	30mm (1 ¹ / ₁₆ ")	0~25mm (0~1")	OVER 420mm (OVER 16 ¹⁷ / ₃₂ ")	5~10mm (³ / ₁₆ "~ ³ / ₈ ")	-5~5mm (- ³ / ₁₆ "~ ³ / ₁₆ ")

When Using Installation Kits

1. Window Requirements

This unit is designed for installation in standard double hung windows with actual opening widths from 27" to 39". The top and bottom window sash must open sufficiently to allow a clear vertical opening of 16" from the bottom of the upper sash to the window stool.

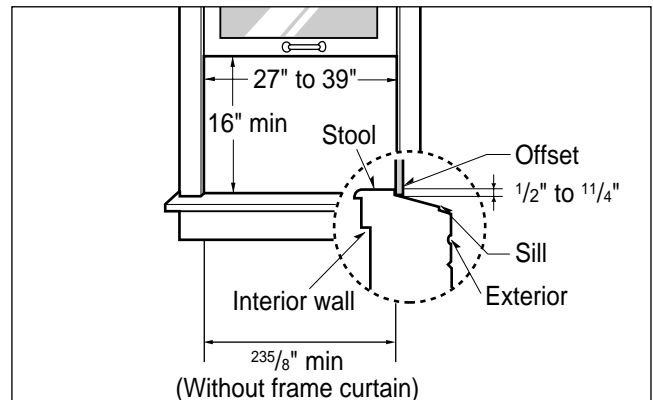

2. Installation Kits Contents

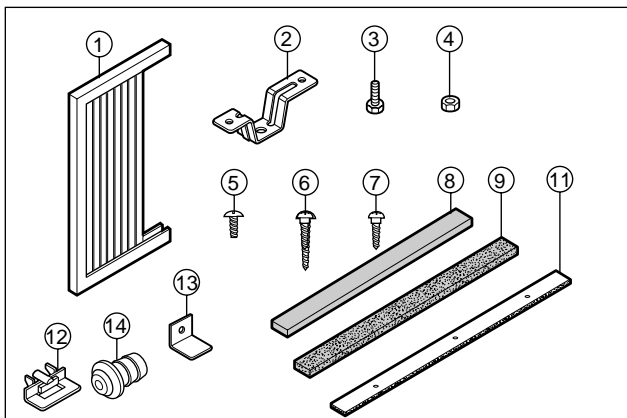

NO.	NAME OF PARTS	Q'TY
1	FRAME CURTAIN	2
2	SILL SUPPORT	2
3	BOLT	2
4	NUT	2
5	SCREW(TYPE A) (10mm(² / ₅ "))	16
6	SCREW(TYPE B) D5.1mm(0.2")/16mm(0.63")	3
7	SCREW(TYPE C) D4.1mm(0.17")/16mm(0.63")	5
8	FOAM-STRIP	1
9	FOAM-PE (920mm x 30mm x 2mm)	1
10	UPPER GUIDE	1
11	FOAM-PE (600mm x 25mm x 2mm)	1
12	FRAME GUIDE	2
13	WINDOW LOCKING BRACKET	1
14	DRAIN PIPE	1

■ Top retainer bar is in the product package.

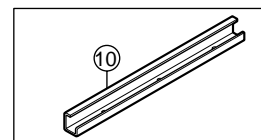

REG-71A

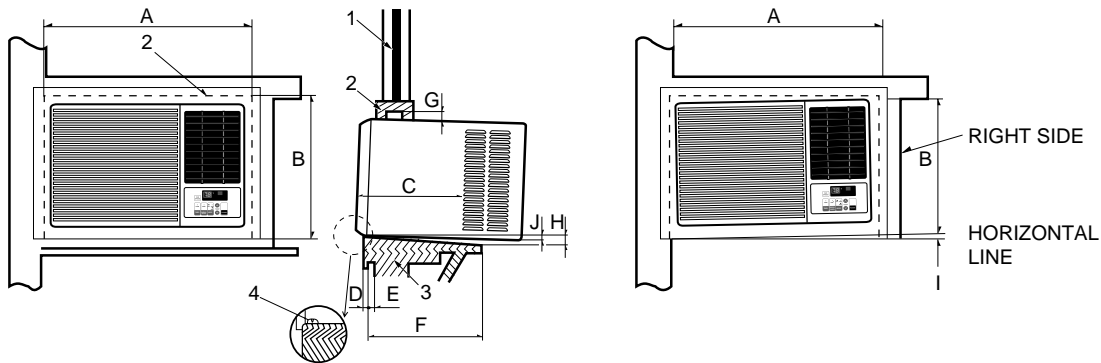

- 1. WINDOW (WIDTH-A, HEIGHT-B)
- 2. GASKET
- 3. WALL

- 4. DETAILS 5.1 x 30 ROUND HEAD WOOD SCREWS

A	B	C	D	E	F	G	H	J	K
495mm (19 1/2")	366mm (14 7/16")	250mm (10")	30mm (1 1/16")	0~25mm (0~1")	OVER 420mm (OVER 16 17/32")	12mm (1/2")	32mm (1 1/4")	5~10mm (3/16"~3/8")	0~5mm (0~3/16")

When Using Installation Kits

1. Window Requirements

This unit is designed for installation in standard double hung windows with actual opening widths from 22" to 36".

The top and bottom window sash must open sufficiently to allow a clear vertical opening of 15" from the bottom of the upper sash to the window stool.

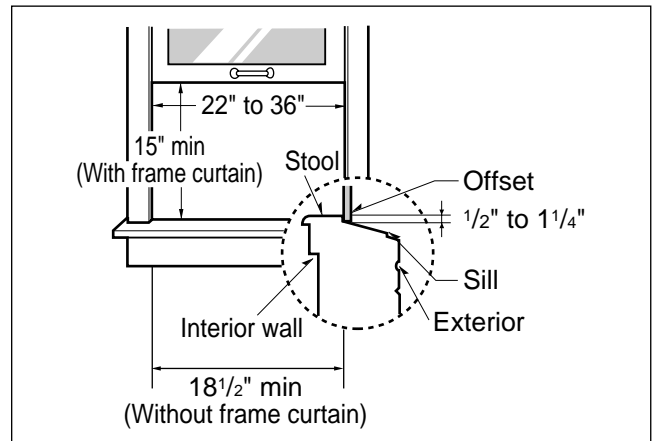

2. Installation Kits Contents

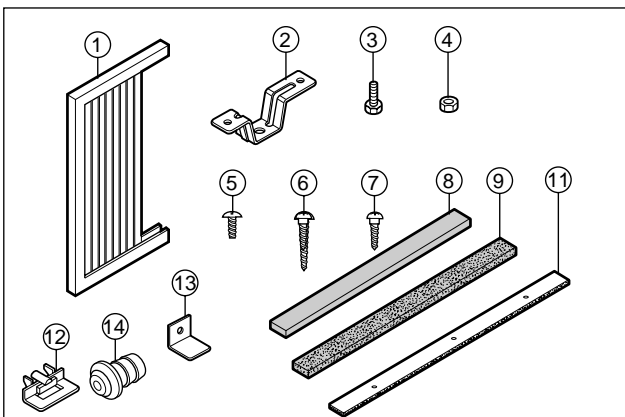

NO.	NAME OF PARTS	Q'TY
1	FRAME CURTAIN	2
2	SILL SUPPORT	2
3	BOLT	2
4	NUT	2
5	SCREW(TYPE A) (10mm(2/5"))	16
6	SCREW(TYPE B) D5.1mm(0.2")/16mm(0.63")	3
7	SCREW(TYPE C) D4.1mm(0.17")/16mm(0.63")	5
8	FOAM-STRIP	1
9	FOAM-PE (920mm x 30mm x 2mm)	1
10	UPPER GUIDE	1
11	FOAM-PE (600mm x 25mm x 2mm)	1
12	FRAME GUIDE	2
13	WINDOW LOCKING BRACKET	1
14	DRAIN PIPE	1

■ Top retainer bar is in the product package.

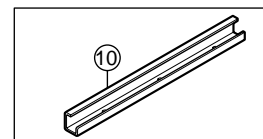

Suggested Tool Requirements

SCREWDRIVER (+, -), RULER, KNIFE, HAMMER, PENCIL, LEVEL

Preparation of Chassis

1. Remove the screws that fasten the cabinet at both sides and at the back.
2. Slide the unit out from the cabinet by gripping the base pan handle and pulling forward while bracing the cabinet.
3. Remove EPS Material.
4. Cut the window sash seal to the proper length. Peel off the backing and attach the foam-pe ⑨ to the underside of the window sash.
5. Remove the backing from the top upper guide Foam PE ⑪ and attach it to the bottom of the upper guide ⑩.
6. Attach the upper guide onto the top of the cabinet with 3 type A screws.
7. Insert the frame guides ⑫ into the bottom of the cabinet.
8. Insert the Frame Curtain ① into the upper guide ⑩ and frame guides ⑫.
9. Fasten the curtains to the unit with 4 Type A screws at the both sides.

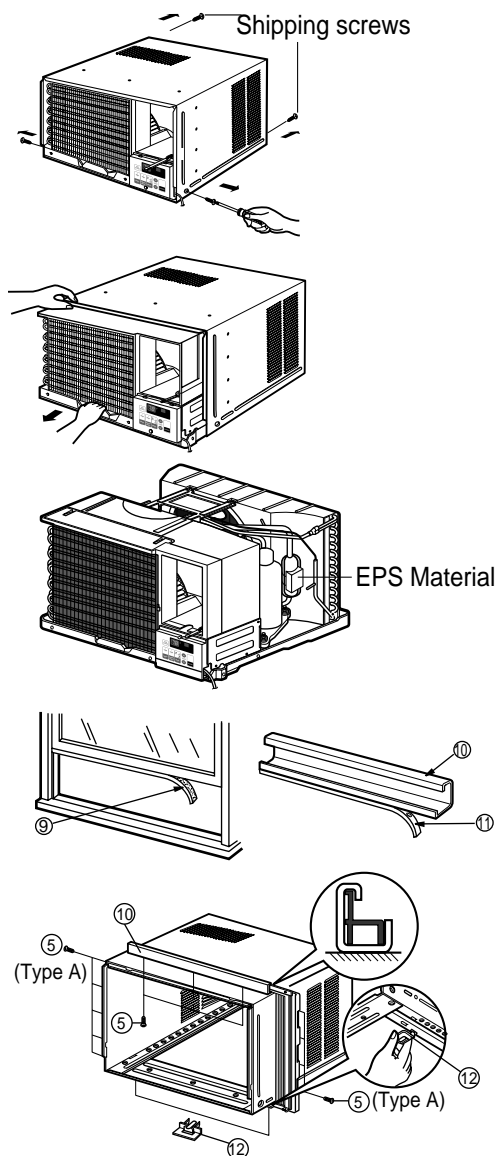

Cabinet Installation

1. Open the window. Mark a line on center of the window sill (or desired air conditioner location). Carefully place the cabinet on the window sill and align the center mark on the bottom front with the center line marked in the window sill.
2. Pull the bottom window sash down behind the upper guide until it meets.

NOTICE Do not pull the window sash down so tightly that the movement of Frame Curtain is restricted.

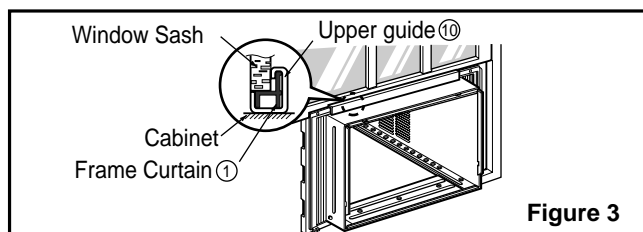
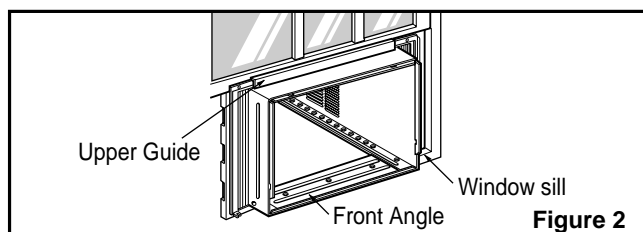

- Loosely assemble the sill support using the parts in Figure 4.

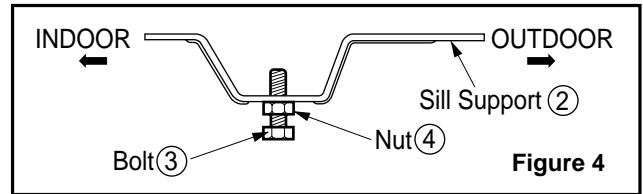

- Select the position that will place the sill support near the outer most point on sill (See Figure 4)

NOTICE Be careful when you install the cabinet (Frame Guides 12 are broken easily).

- Attach the sill support to the cabinet track hole in relation to the selected position using 2 Type A screws in each support (See Figure 5).

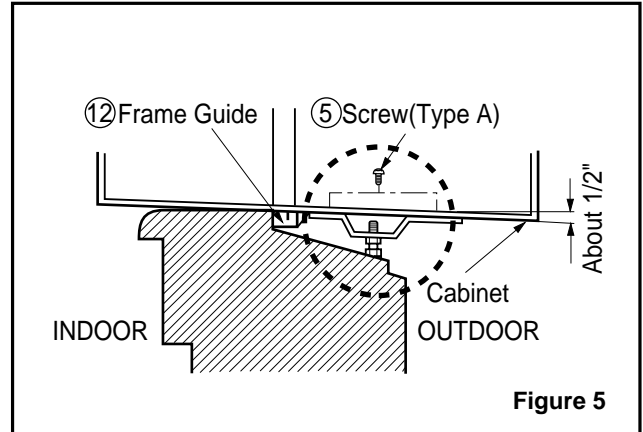

- The cabinet should be installed with a very **slight tilt (about 1/2") downward** toward the outside (See Figure 6).
Adjust the bolt and the nut of Sill Support for balancing the cabinet.

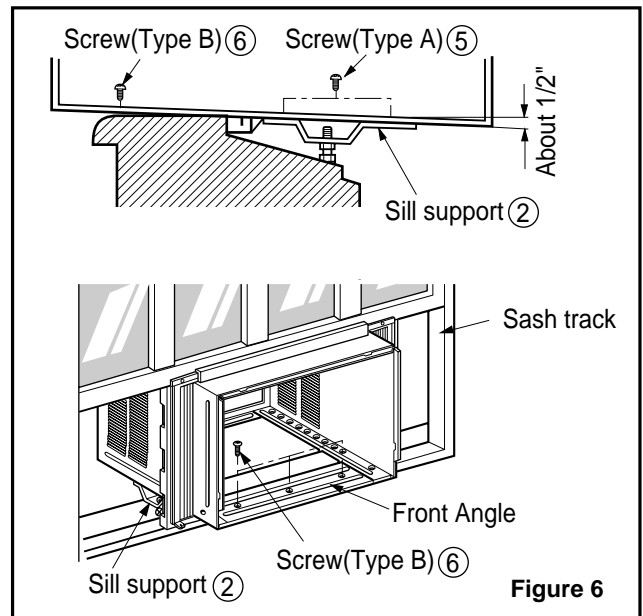

- Attach the cabinet to the window stool by driving the screws 6 (Type B) through the front angle into window stool (5/8").
- Pull each Frame Curtain properly to each window sash track, and repeat step 2.

- Attach each Frame Curtain to the window sash by using screws 7 (Type C). (See Figure 7)

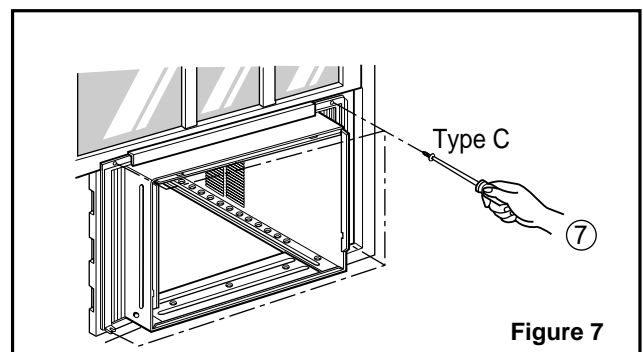

10. Slide the unit into the cabinet.(See Fig. 8)

CAUTION: For security purpose, reinstall screws (Type A) at the cabinet's sides.

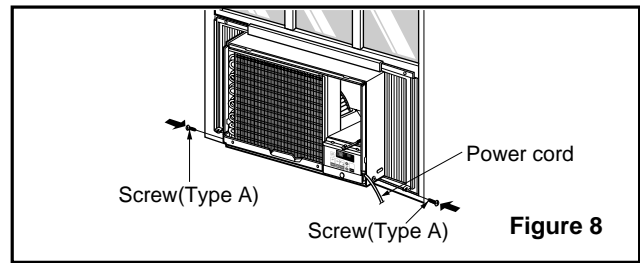

Figure 8

11. Cut the Foam-Strip ⑧ to the proper length and insert between the upper and lower window sash. (See Fig. 9)

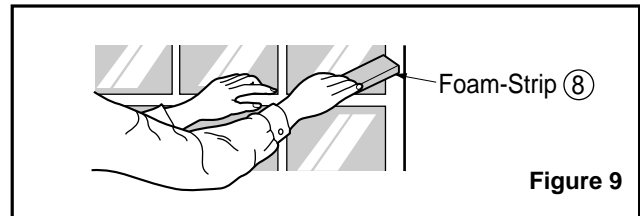

Figure 9

12. Attach the window Locking Bracket ⑬ with a type C screw. (See Fig. 10)

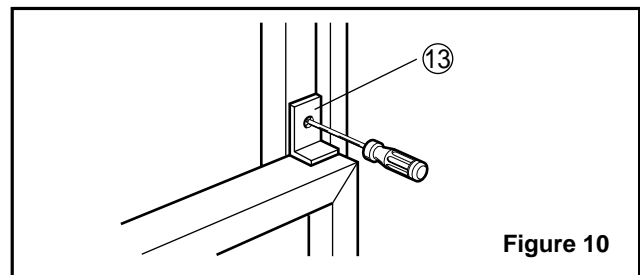

Figure 10

13. Attach the front grille to the cabinet by inserting the tabs on the grille into the tabs on the front of the cabinet. Push the grille in until it snaps into place. (See Fig. 11)

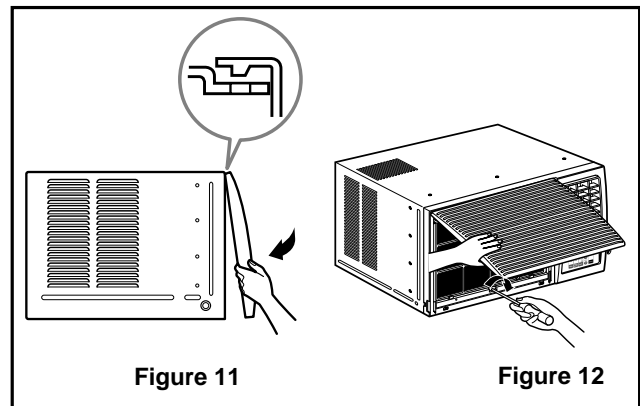

Figure 11

Figure 12

14. Lift the inlet grille and secure it with a type A screw through the front grille.(See Fig. 12)

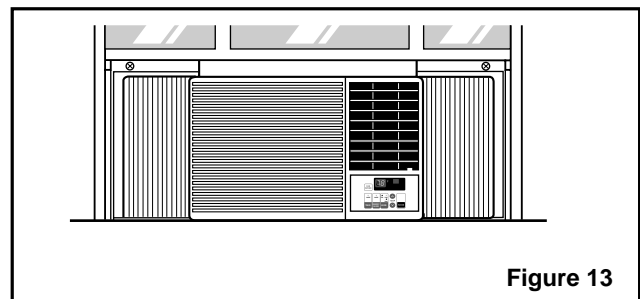

Figure 13

Operation

Features

- Designed for COOLING and HEATING.
- Powerful and whispering cooling.
- Slide-in and slide-out chassis for the simple installation and service.
- Side air-intake, side cooled-air discharge.
- Built-in adjustable THERMOSTAT
- Washable one-touch filter
- Compact size
- Reliable and efficient rotary compressor

Control Locations Function of Controls

• VENTILATION

The ventilation lever must be in the CLOSE position in order to maintain the best cooling conditions.

When a fresh air is necessary in the room, set the ventilation lever to the OPEN position.

The damper is opened and room air is exhausted.

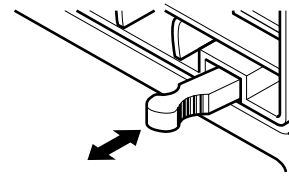

CLOSE VENT OPEN

1. POWER BUTTON

To turn the air conditioner ON, push the button. To turn the air conditioner OFF, push the button again.

This button takes priority over any other buttons.

2. OPERATION MODE SELECTION BUTTON

Everytime you push this button, it will toggle COOL, FAN and HEAT.

3. ON/OFF TIMER BUTTON

Everytime you push this button, timer is set as follows.(1Hour → 2Hours → 3Hours → 4Hours → 5Hours → 6Hours → 7Hours → 8Hours → 9Hours → 10Hours → 11Hours → 12Hours → Cancel)

4. FAN SPEED SELECTOR

Everytime you push this button, it is set as follows. (Hi[F2] → Low[F1] → Hi[F2]....)

5. ROOM TEMPERATURE SETTING BUTTON

This button can automatically control the temperature of the room. The temperature can be set within a range of 60°F to 86°F by 1°F.

6. ENERGY SAVER

The fan stops when the compressor stops cooling. Approximately every 3 minutes the fan will turn on and check the room air to determine if cooling is needed.

7. REMOCON SIGNAL RECEIVER

8. AUTO SWING

This button can automatically control the air flow direction.

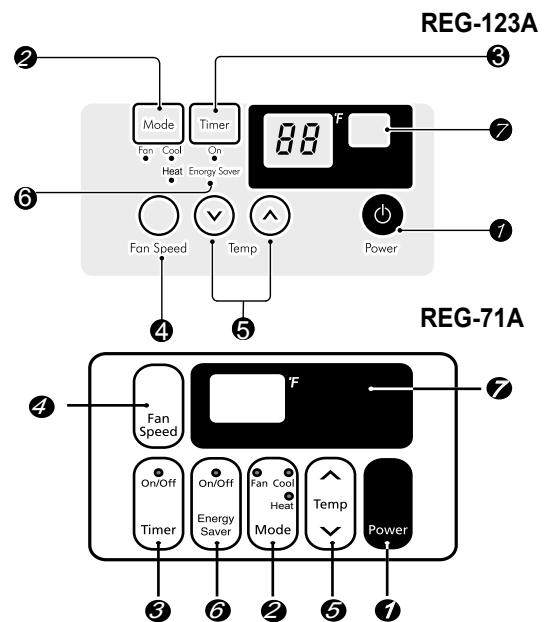

REMOTE CONTROLLER

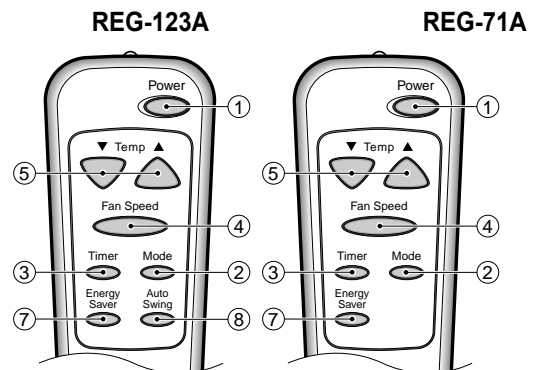

CAUTION: A slight heat odor may come from the unit when first switching to HEAT after the cooling season is over. This odor, caused by fine dust particles on the heater, will disappear quickly.

Disassembly

— Before the following disassembly, **CONTROL BOX** set to OFF and disconnect the power cord.

Mechanical Parts

1. Front Grille

1. Open the Inlet grille upward .
2. Remove the screw that fastens the front grille.
3. Pull the front grille from the right side.
4. Remove the front grille.
5. Re-install the component by referring to the removal procedure, above.(See Figure 14)

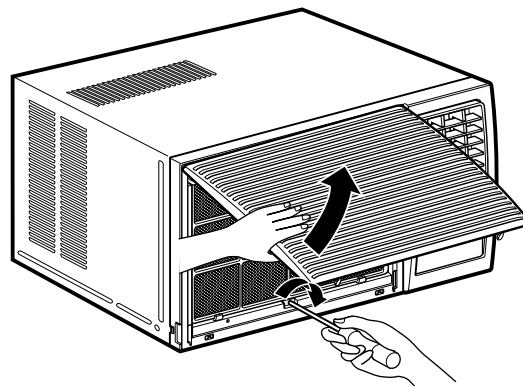

Figure 14

2. Cabinet

1. After disassembling the FRONT GRILLE, remove the 2 screws that fasten the cabinet at both sides.
2. Remove the 2 screws that fasten the cabinet at back.
3. Pull the base pan forward. (See Figure 15)
4. Remove the cabinet.
5. Re-install the component by referring to the removal procedure, above.

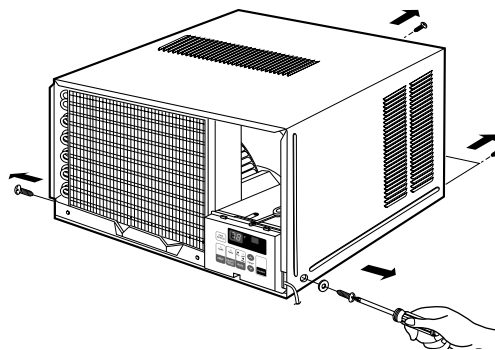

Figure 15

3. Control Box

1. Remove the front grille. (Refer to section 1)
2. Remove the cabinet. (Refer to section 2)
3. Remove the 2 screws that fasten the control box cover.
4. Remove two housings that connect compressor wire and motor wire in the control box.
5. Discharge the capacitor by placing a 20,000 ohm resistor across the capacitor terminals.
6. Remove the 2 screws that fasten the control box.
7. Pull the control box forward completely.
8. Re-install the components by referring to the removal procedure, above. (See Figure 16)
(Refer to the circuit diagram found on page 23 in this manual and on the control box.)

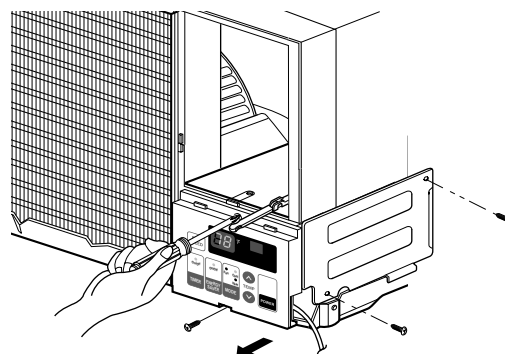

Figure 16

Air Handling Parts

4. Air Guide and Turbo Fan

1. Remove the front grille. (Refer to section 1)
2. Remove the cabinet. (Refer to section 2)
3. Remove the control box. (Refer to section 3)
4. Remove the 4 screws that fasten the brace.
5. Remove the brace.
6. Remove the 2 screws that fasten the evaporator.
7. Move the evaporator forward and pulling it upward slightly. (See Figure 17)
8. Move the evaporator to the left carefully.
9. Remove the 2 terminals carefully. (See Figure 18, at Electric heater Model)
10. Remove the 3 screws that fasten the Heater Cover. (See Figure 18, at Electric Heater Model)
11. Remove the Heater cover. (See Figure 18, at Electric Heater Model)
12. Pull out the hook of orifice by pushing the tabs and remove it. (See Figure 19)
13. Remove the clamp with a hand plier that secures the blower.
14. Remove the blower.
15. Remove the 4 screws that fasten the air guide from the barrier.
16. Move the air guide backward, pulling out from the base pan.
17. Re-install the components by referring to the removal procedure, above.

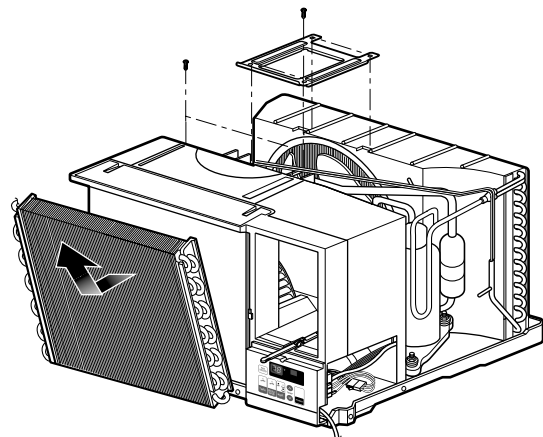

Figure 17

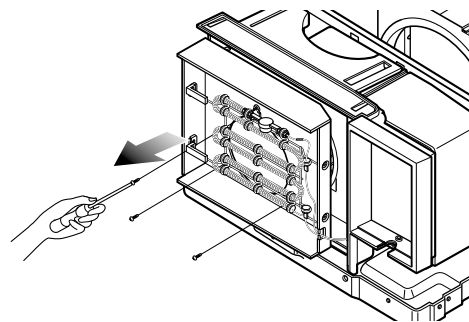

Figure 18

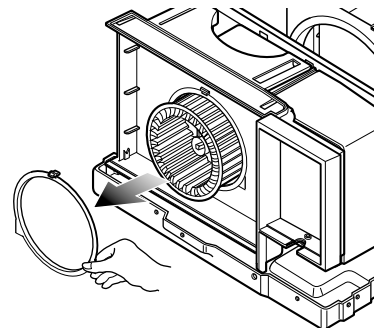

Figure 19

5. FAN

1. Remove the cabinet. (Refer to section 2)
2. Remove the brace (Refer to section 4)
3. Remove the 4 screws that fasten the condenser.
4. Move the condenser to the left carefully.
5. Remove the clamp that secures the fan.
6. Remove the fan. (See Figure 20)
7. Re-install by referring to the removal procedure.

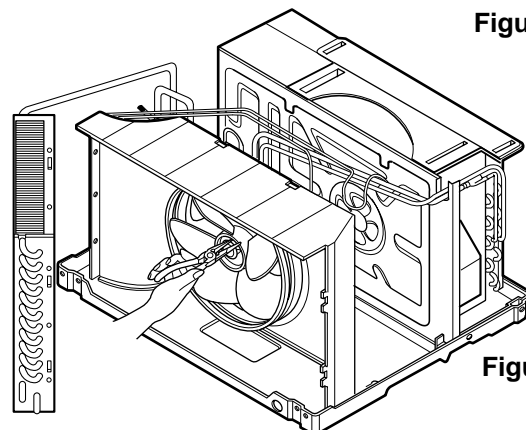

Figure 20

6. Shroud

1. Remove the fan. (Refer to section 5)
2. Remove the screw that fastens the shroud.
3. Remove the shroud. (See Figure 21)
4. Re-install the component by referring to the removal procedure, above.

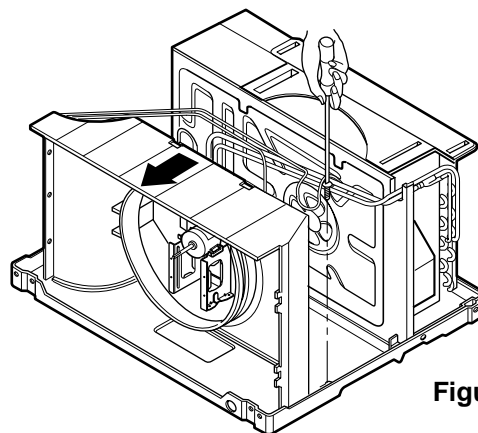

Figure 21

Electrical Parts

7. Overload Protector

1. Remove the cabinet. (Refer to section 2)
2. Remove the nut that fastens the terminal cover.
3. Remove the terminal cover. (See Figure 22)
4. Remove all the leads from the overload protector.
5. Remove the overload protector.
6. Re-install the component by referring to the removal procedure, above.

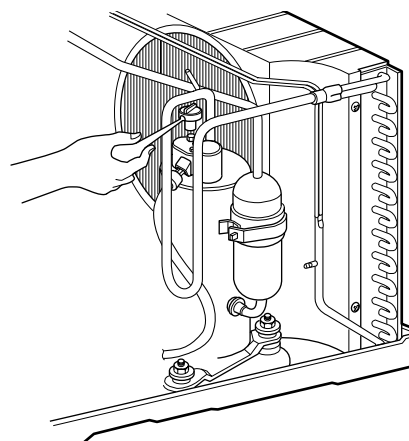

Figure 22

8. Compressor

1. Remove the cabinet. (Refer to section 2)
2. Discharge the refrigerant system using a Freon™ Recovery System.
If there is no valve to attach the recovery system, install one (such as a Watco A-1) before venting the Freon™. Leave the valve in place after servicing the system.
3. Remove the overload protector. (Refer to section 7)
4. After purging the unit completely, unbraid the suction and discharge tubes at the compressor connections.
5. Remove the 3 nuts and the 3 washers that fasten the compressor.
6. Remove the compressor. (See Figure 23)
7. Re-install the components by referring to the removal procedure, above.

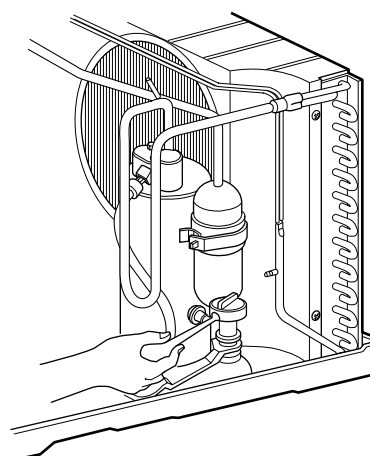

Figure 23

9. Capacitor

1. Remove the control box. (Refer to section 3)
2. Remove the knobs and the screw that fasten control panel from control box.
3. Remove the screw that located in the front.
4. Open the bottom side of control box.
5. Remove the screw and the clamp that fastens the capacitor.
6. Disconnect all the leads of capacitor terminals.
7. Re-install the components by referring to the removal procedure, above. (See Figure 24)

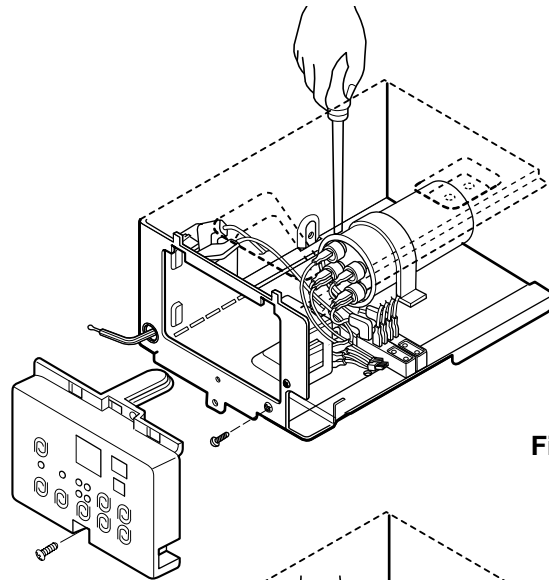

Figure 24

10. Power Cord

1. Remove the control box. (Refer to section 3)
2. Open the control box. (Refer to section 9)
3. Disconnect the grounding screw from the control box.
4. Disconnect the 2 receptacles.
5. Remove a screw which fastens the clip cord. (See Figure 25)
6. Remove the power cord.
7. Re-install the component by referring to the above removal procedure, above. (Use only one ground-marked hole \oplus for ground connection.)
8. If the supply cord of this appliance is damaged, it must be replaced by the special cord. (The special cord means the cord that has the same specification marked on the supply cord attached at the unit.)

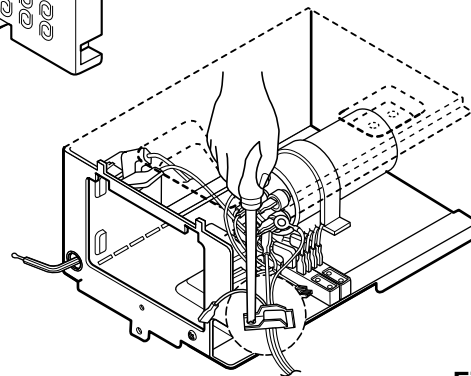

Figure 25

11. Thermistor

1. Remove the control box. (Refer to section 3)
2. Open the control box. (Refer to section 6)
3. Disconnect the thermistor terminals from main P.W.B assembly.
4. Remove the thermistor.
5. Re-install the components by referring to the above removal procedure. (See Figure 26)

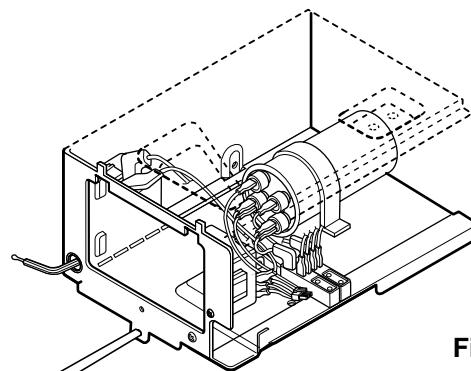

Figure 26

12. SYNCHRONOUS MOTOR

1. Remove the control box. (Refer to section 3)
2. Unfold the control box. (Refer to section 10)
3. Remove the crankshaft.
4. Disconnect all the leads of the synchronous motor.
5. Remove the 2 screws which fasten the synchronous motor. (See Fig. 27)
6. Re-install the components by referring to the removal procedure, above.

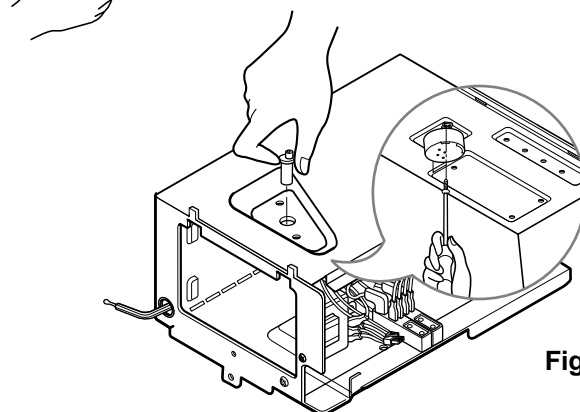

Figure 27

13. Motor

1. Remove the cabinet. (Refer to section 2)
2. Remove the evaporator. (Refer to section 4)
3. Remove the orifice. (Refer to section 4)
4. Remove the blower. (Refer to section 4)
5. Remove the fan. (Refer to section 5)
6. Remove the control box cover and disconnect 5 or 4 wires of motor housing. (Refer to section 3)
7. Remove the 2 or 4 screws that fasten the motor from the mount motor. (See Figure 28)
8. Remove the motor.
9. Re-install the components by referring to the removal procedure, above.(See Figure 28)

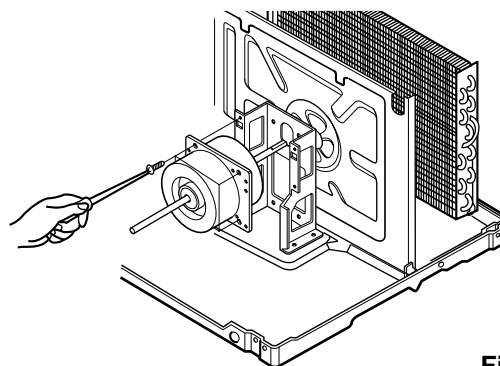

Figure 28

Refrigerating Cycle

⚠ CAUTION: Discharge the refrigerant system using a Freon™ Recovery System. If there is no valve to attach the recovery system, install one (such as a WATCO A-1) before venting the Freon™. Leave the valve in place after servicing the system.

14. Condenser

1. Remove the cabinet. (Refer to section 2)
2. Remove the 4 screws that fasten the brace.(Refer to section 4)
3. Remove the 5 screws that fasten the condenser and shroud.
4. After discharging the refrigerant completely, unbrazed the interconnecting tube at the condenser connections.
5. Remove the condenser.
6. Re-install the component by referring to notes. (See Figure 29)

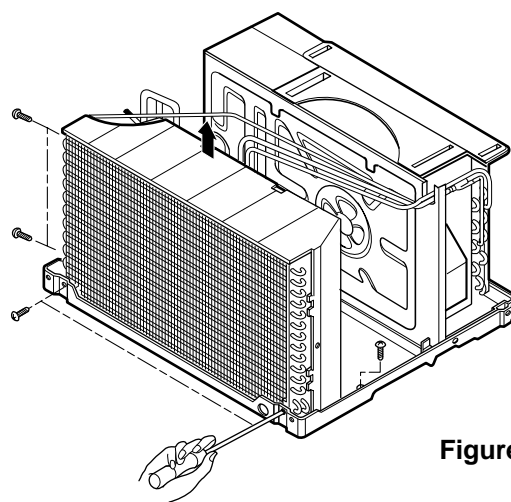

Figure 29

15. Evaporator

1. Remove the cabinet. (Refer to section 2)
2. Remove the 2 screws that fasten the evaporator.
3. Move the evaporator sideways carefully. (Refer to section 4)
4. After discharging the refrigerant completely, unbrazed the interconnecting tube at the evaporator connections.
5. Remove the evaporator.
6. Re-install the component by referring to notes. (See Figure 30)

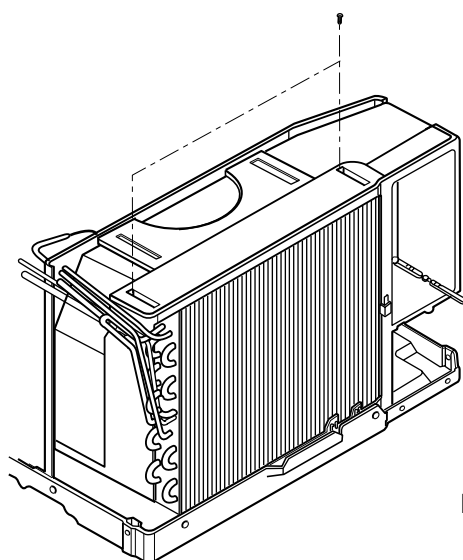

Figure 30

16. Capillary Tube

1. Remove the cabinet. (Refer to section 2)
2. After discharging the refrigerant completely, unbraid the interconnecting tube at the capillary tube. (See caution above)

NOTICE

— Replacement of the refrigeration cycle.

1. When replacing the refrigeration cycle, be sure to discharge the refrigerant system using a Freon™ recovery System.
If there is no valve to attach the recovery system, install one (such as a WATCO A-1) before venting the Freon™. Leave the valve in place after servicing the system.
2. After discharging the unit completely, remove the desired component, and unbraid the pinch-off tubes.
3. Solder service valves into the pinch-off tube ports, leaving the valves open.
4. Solder the pinch-off tubes with Service valves.
5. Evacuate as follows.
 - 1) Connect the vacuum pump, as illustrated figure 31A.
 - 2) Start the vacuum pump, slowly open manifold valves A and B with two full turns counterclockwise and leave the valves open.
The vacuum pump is now pulling through valves A and B up to valve C by means of the manifold and entire system.

 **CAUTION: If high vacuum equipment is used, just crack valves A and B for a few minutes, then open slowly with the two full turns counterclockwise. This will keep oil from foaming and being drawn into the vacuum pump.**

- 3) Operate the vacuum pump vacuum for 20 to 30 minutes, until 600 microns of vacuum is obtained. Close valves A and B, and observe vacuum gauge for a few minutes. A rise in pressure would indicate a possible leak or moisture remaining in the system. With valves A and B closed, stop the vacuum pump.
- 4) Remove the hose from the vacuum pump and place it on the charging cylinder. See figure 31B. Open valve C.
Discharge the line at the manifold connection.
- 5) The system is now ready for final charging.

3. Remove the capillary tube.
4. Re-install the component by referring to notes.

6. Recharge as follows :

- 1) Refrigeration cycle systems are charged from the High-side. If the total charge cannot be put in the High-side, the balance will be put in the suction line through the access valve which you installed as the system was opened.
- 2) Connect the charging cylinder as shown in figure 31B.
With valve C open, discharge the hose at the manifold connection.
- 3) Open valve A and allow the proper charge to enter the system. Valve B is still closed.
- 4) If more charge is required, the high-side will not take it. Close valve A.
- 5) With the unit running, open valve B and add the balance of the charge.
 - a. Do not add the liquid refrigerant to the Low-side.
 - b. Watch the Low-side gauge; allow pressure to rise to 30 lbs.
 - c. Turn off valve B and allow pressure to drop.
 - d. Repeat steps b. and c. until the balance of the charge is in the system.
- 6) When satisfied the unit is operating correctly, use the pinch-off tool with the unit still running and clamp on to the pinch-off tube. Using a tube cutter, cut the pinch-off tube about 2 inches from the pinch-off tool. Use sil-fos braze and braze pinch-off tube closed. Turn off the unit, allow it to set for a while, and then test the leakage of the pinch-off connection.

Equipment needed: Vacuum pump, Charging cylinder, Manifold gauge, Brazing equipment. Pinch-off tool capable of making a leak-proof seal, Leak detector, Tubing cutter, Hand Tools to remove components, Service valve.

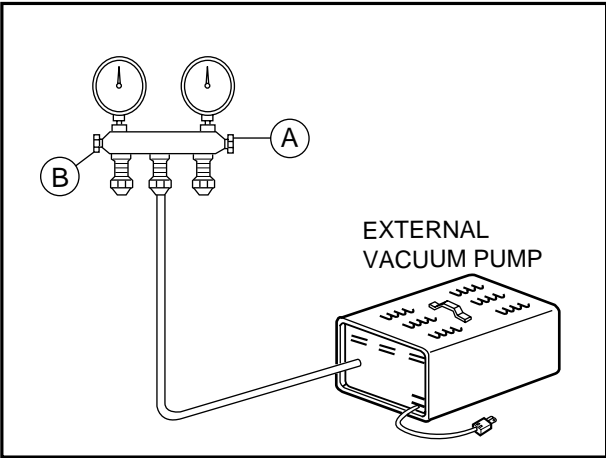
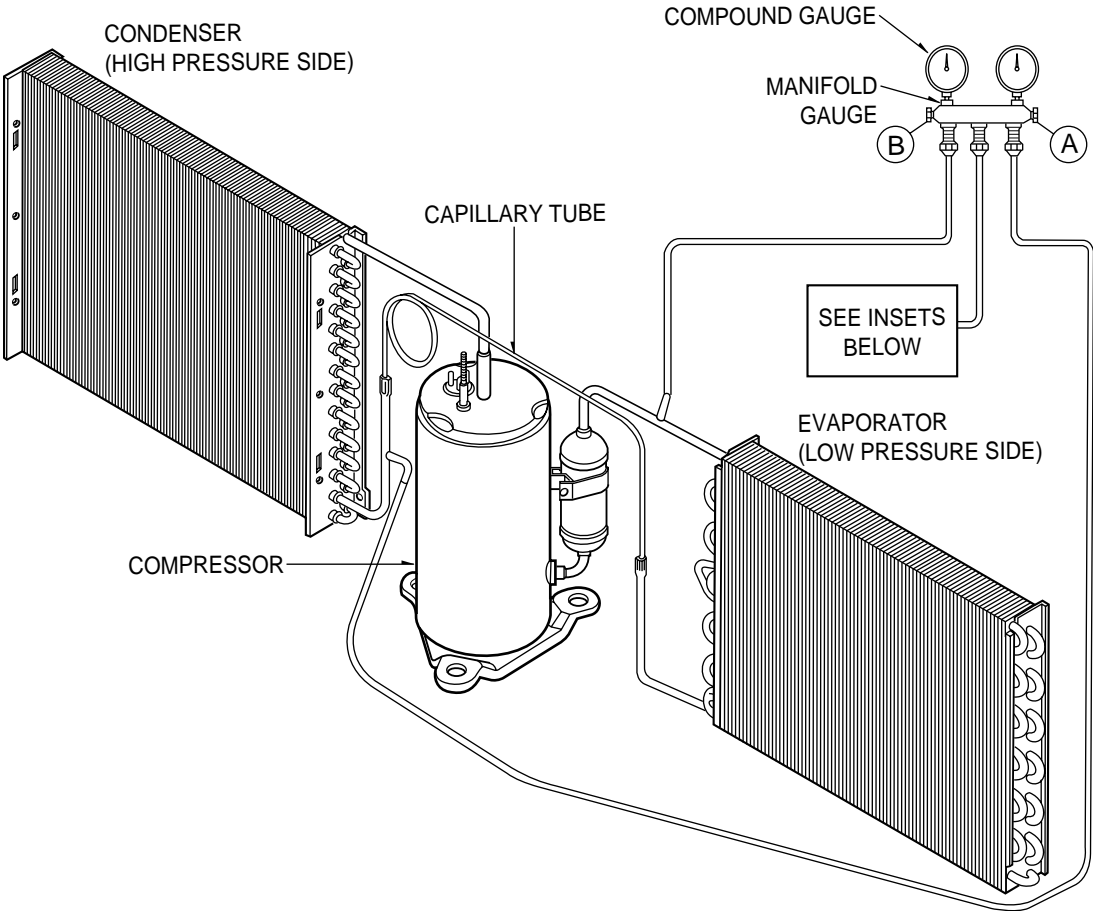

Figure 31A-Pulling Vacuum

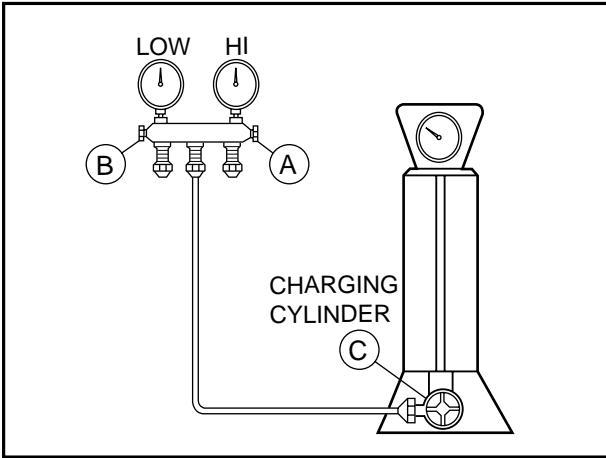
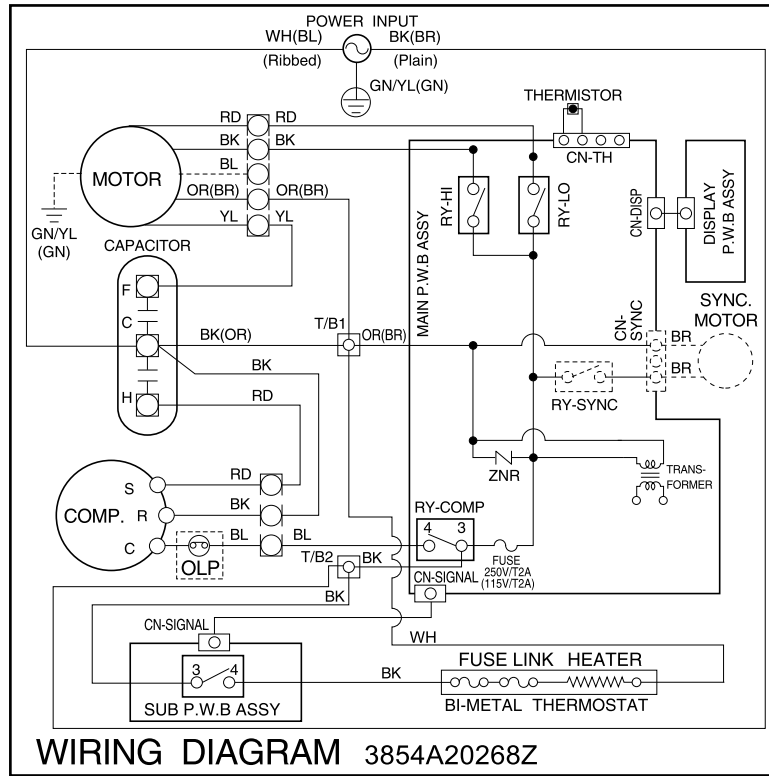

Figure 31B-Charging

Schematic Diagram

Wiring Diagram

■ ELECTRIC HEATING MODEL



Troubleshooting Guide

Piping System

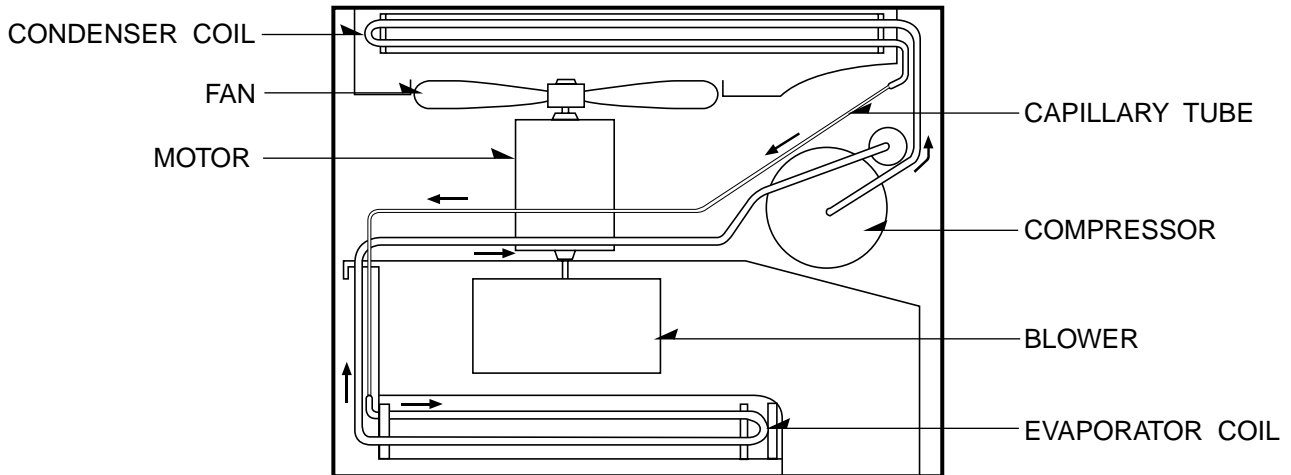
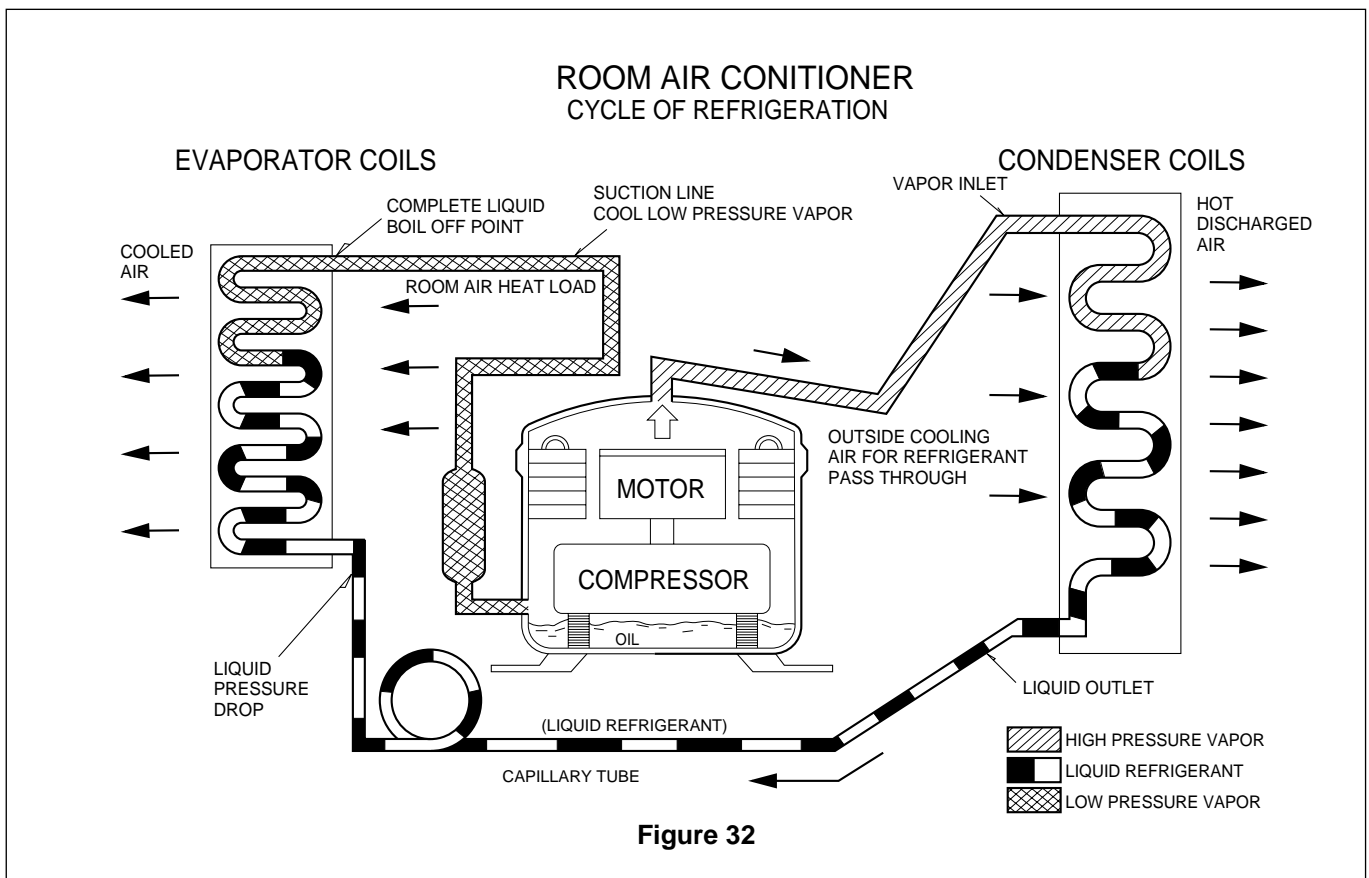

Figure 32 is a brief description of the important components and their function in what is called the refrigeration system. This will help you to understand the refrigeration cycle and the flow of the refrigerant in the cooling cycle.



Troubleshooting Guide

In general, possible trouble is classified in two kinds.

The one is called Starting Failure which is caused from an electrical defect, and the other is ineffective Air Conditioning caused by a defect in the refrigeration circuit and improper application.

Unit runs but poor cooling.

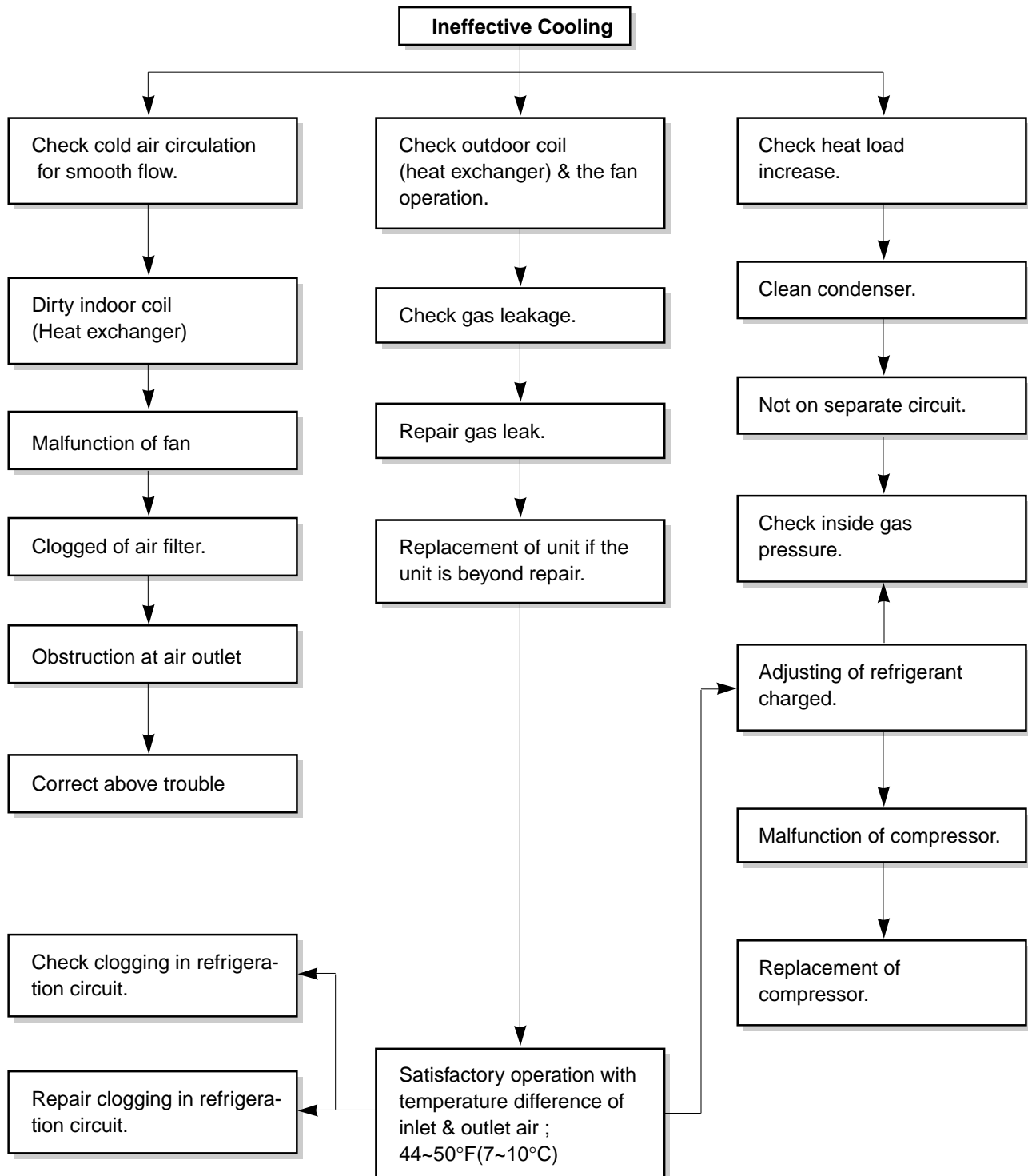

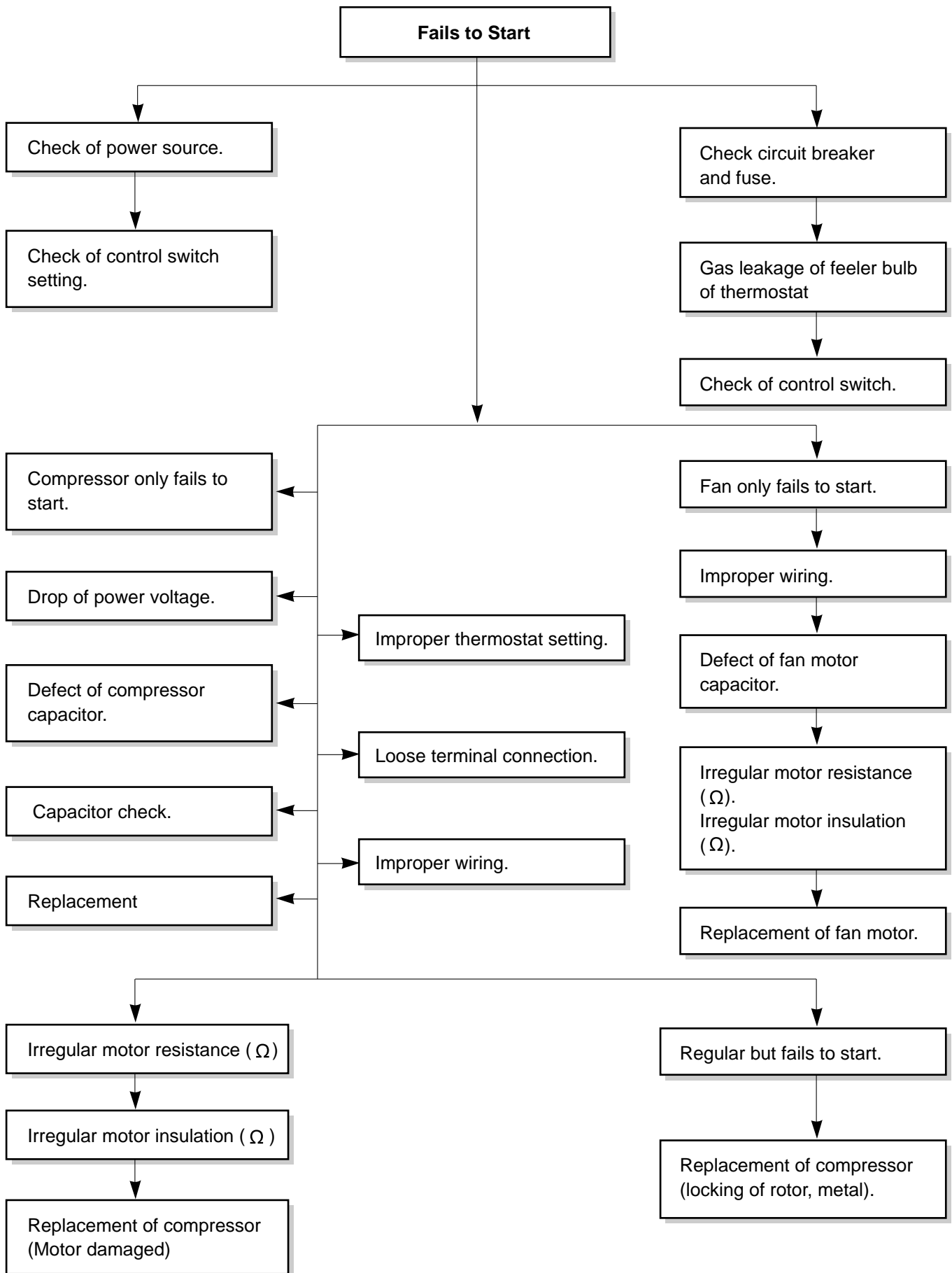

Room Air Conditioner Voltage Limits

NAME PLATE RATING	MINIMUM	MAXIMUM
208~230±10%	187V	253V
115±10%	104V	126V

COMPLAINT	CAUSE	REMEDY
Fan motor will not run.	No power	Check voltage at outlet. Correct if necessary.
	Power supply cord	Check voltage to rotary switch. If none, check power supply cord. Replace cord if circuit is open.
	Rotary switch	Check switch continuity. Refer to wiring diagram for terminal identification. Replace switch if defective.
	Wire disconnected or connection loose	Connect wire. Refer to wiring diagram for terminal identification. Repair or replace loose terminal.
	Capacitor (Discharge capacitor before testing.)	Test capacitor. Replace if not within ±10% of manufacturer's rating. Replace if shorted, open, or damaged.
	Will not rotate	Fan blade hitting shroud or blower wheel hitting scroll. Realign assembly. Units using slinger ring for condenser fan must have 1/4 to 5/16 inch clearance to the base. If it hits the base, shim up the bottom of the fan motor with mounting screw(s). Check fan motor bearings; if motor shaft will not rotate, replace the motor.
Fan motor runs intermittently	Revolves on overload.	Check voltage. If not within limits, call an electrician. Test capacitor. Check bearings. Does the fan blade rotate freely? If not, replace fan motor. Pay attention to any change from high speed to low speed. If the speed does not change, replace the motor.
Fan motor noise.	Fan	If cracked, out of balance, or partially missing, replace it.
	Blower	If cracked, out of balance, or partially missing, replace it.
	Loose clamper	Tighten it.
	Worn bearings	If knocking sounds continue when running or loose, replace the motor. If the motor hums or noise appears to be internal while running, replace motor.
Compressor will not run, but fan motor runs.	Voltage	Check voltage. If not within limits, call an electrician.
	Wiring	Check the wire connections, if loose, repair or replace the terminal. If wires are off, refer to wiring diagram for identification, and replace. Check wire locations. If not per wiring diagram, correct.
	Rotary	Check for continuity, refer to the wiring diagram for terminal identification. Replace the switch if circuit is open.

COMPLAINT	CAUSE	REMEDY
Compressor will not run, but fan motor runs.	Thermostat	Check the position of knob. If not at the coldest setting, advance the knob to this setting and restart unit. Check continuity of the thermostat. Replace thermostat if circuit is open.
	Capacitor (Discharge capacitor before servicing.)	Check the capacitor. Replace if not within $\pm 10\%$ of manufacturer's rating. Replace if shorted, open, or damaged.
	Compressor	Check the compressor for open circuit or ground. If open or grounded, replace the compressor.
	Overload	Check the compressor overload, if externally mounted. Replace if open. (If the compressor temperature is high, remove the overload, cool it, and retest.)
Compressor cycles on overload.	Voltage	Check the voltage. If not within limits, call an electrician.
	Overload	Check overload, if externally mounted. Replace if open. (If the compressor temperature is high, remove the overload, cool, and retest.)
Compressor cycles on overload.	Fan motor	If not running, determine the cause. Replace if required.
	Condenser air flow restriction	Remove the cabinet. Inspect the interior surface of the condenser; if restricted, clean carefully with a vacuum cleaner (do not damage fins) or brush. Clean the interior base before reassembling.
	Condenser fins (damaged)	If condenser fins are closed over a large area on the coil surface, head pressures will increase, causing the compressor to overload. Straighten the fins or replace the coil.
Compressor cycles on overload.	Capacitor	Test capacitor.
	Wiring	Check the terminals. If loose, repair or replace.
	Refrigerating system	Check the system for a restriction.
Insufficient cooling or heating	Air filter	If restricted, clean or replace.
	Exhaust damper door	Close if open.
	Unit undersized	Determine if the unit is properly sized for the area to be cooled.
Excessive noise	Blower or fan	Check the set screw or clamp. If loose or missing, correct. If the blower or fan is hitting air guide, rearrange the air handling parts.
	Copper tubing	Remove the cabinet carefully and rearrange tubing not to contact cabinet, compressor, shroud, and barrier.
Auto air-swing fails.	Rotary switch.	Set the knob to HIGH COOL or LOW COOL while rocker switch is ON.
	Wiring	Check terminals. If loose, repair or replace.
	Synchronous motor.	Check the synchronous motor for open circuit.

Specifications and performance data subject to change without notice.

HEAT CONTROLLER, INC.

1900 WELLWORTH AVENUE • JACKSON, MICHIGAN 49203

THE QUALITY LEADER IN CONDITIONING AIR

04/18/07